

# SR-LD Serie

Single stage  
industrial cleaning machines



Stainless steel construction.  
Closed liquid circuit.  
Rotating spray system

For Production, reparation and  
service workshops.  
Wide selection of accessories.

## Single stage Industrial cleaning machine with mechanical lift door

Technical Data	SR-1.3	SR-1.7	SR-2.0	SR-2.5
Tank Volume (l)	700	1000	1500	2 200
Heating effect (kW)	12	24	36	48
Pump Flow (l/min)	300	400	500	620
Pump Pressure (bar)	4	4,5	4,5	5
Drying effect (kW) <sup>1)</sup>	13, / 18 / 22,5 / 27			
Connection 3x400V, 50Hz, 3x (A)	32	50	63	100

1) Drying is available as an option

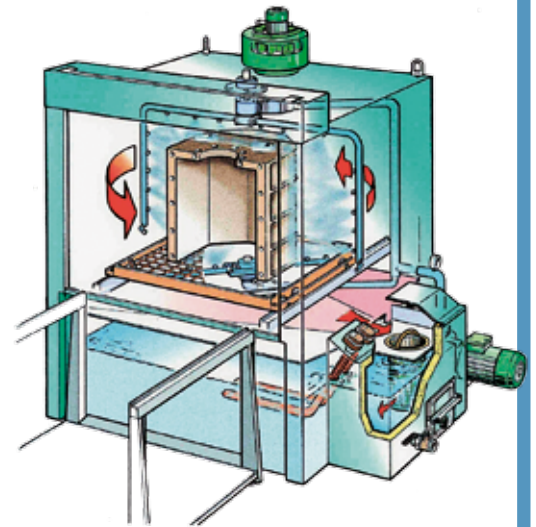

Dimensions (mm)		SR-1.3	SR-1.7	SR-2.0	SR-2.5
Width	A	2 100	2 600	2 950	3 500
Depth	Frame, B	1 600	2 000	2 300	2 800
	Load platform, B1	1 200	1 500	1 700	2 100
Height	Frame, C	2 300	2 300	2 300	2 300
	Loading height, C1	900	900	900	900
	Door open, C3	3 300	3 300	3 300	3 300

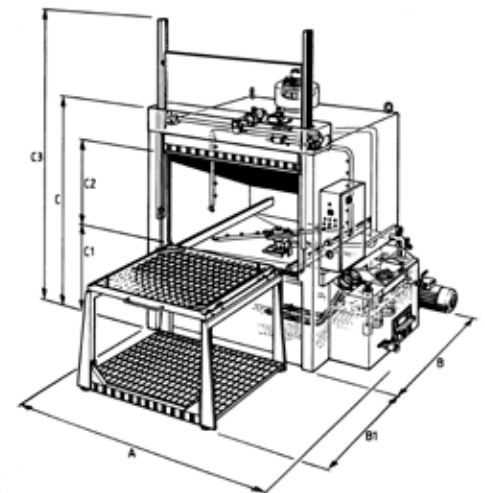

Part Dimensions		SR-1.3	SR-1.7	SR-2.0	SR-2.5
Height <sup>2)</sup>	mm	900	900	900	900
Diameter ø	mm	1 100	1 500	1 800	2 300
Load <sup>3)</sup>	kg	800	800	1 000	2 000

2) Bigger heights available as an option

3) Bigger loads available as an option

### Accessories

- Oil separators
- Filter systems
- Detergent dosing units
- Drying
- Automation

More information on accessories  
from our dealer

Sampo Rosenlew Ltd  
Konepajanranta 2 A  
P.O. Box 50  
FI-28101 PORI, FINLAND

Tel. +358207 550555  
Fax +35826326546  
www.sampo-rosenlew.fi

The manufacturer reserves the right to any changes on product or specifications. Images and specifications may vary from the original