

LD series

Two stage industrial cleaning machines



Closed liquid circuit.
Rotating spraying.

For production, maintenance and
service purposes.

Final cleaning before assembly.
Surface handling before painting.

Wide selection of accessories..

Two stage industrial cleaning machine

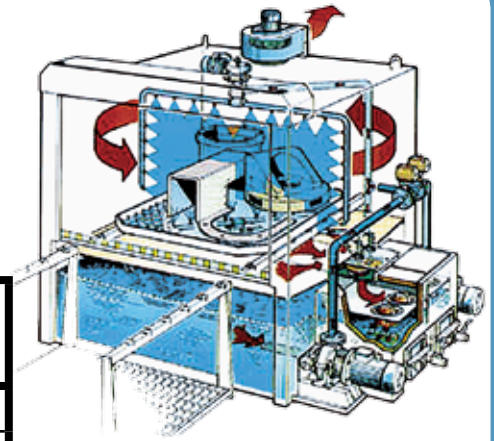

Technical Data	Tank	SR-1.3-2	SR-1.7-2	SR-2.0-2	SR-2.5-2
Tank Volume (l)	1	500	800	1100	1400
	2	400	600	800	1200
Heating power (kW)	1	24	24	36	48
	2	12	12	24	24
Pump Flow (l/min)	1	300	400	500	620
	2	260	350	390	500
Pump Pressure (bar)	1	4	4,5	4,5	5
	2	2,5	2,5	2,5	3
Motor (kW)	1	4	7,5	7,5	11
	2	2,2	3	4	4
Electric Connection 3x400V 50Hz, 3x (A)		63	80	100	125

Dimensions (mm)		SR-1.3-2	SR-1.7-2	SR-2.0-2	SR-2.5-2
Width	A	2250	2650	3000	3500
Depth	Frame, B	1600	2000	2300	2800
	Loadplatform, B1	1200	1500	1700	2100
Height	Frame, C	2300	2300	2300	2300
	Loading height, C1	900	900	900	900
	Door open, C3	3300	3300	3300	3300

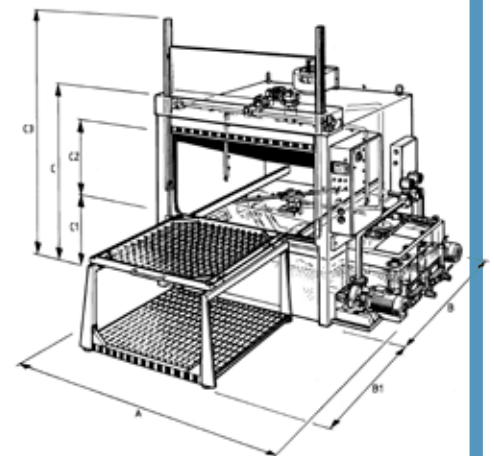

Load Dimensions (mm)		SR-1.3-2	SR-1.7-2	SR-2.0-2	SR-2.5-2
Height ¹⁾	mm	900	900	900	900
Diameter ø	mm	1100	1500	1800	2300
Load ²⁾	kg	800	800	1000	2000

1) Also other heights as options.
2) Bigger load as an option.

Accessories

- Oil separator
- Filtration systems
- Detergent dosage units
- Drying
- Automation

The manufacturer reserves the right to any changes on product or specifications. Images and specifications may vary from the original

Sampo Rosenlew Ltd
Konepajanranta 2 A
P.O. Box 50
FI-28101 PORI, FINLAND

Tel. +358 207 550 555
Fax +358 2632 6546
www.sampo-rosenlew.fi