

SR-LD Series

3-stage Industrial cleaning machines



When higher cleanness is required.
Closed liquid circuit.
Rotating spray system.

For production, maintenance and service purposes.

Final cleaning before assembly.
Surface handling before painting.

Wide selection of accessories..

3-stage industrial cleaning machine

Technical Data	Tank	SR-1.3-3	SR-1.7-3	SR-2.0-3	SR-2.5-3
Tank Volume (l)	1	400	700	800	1 200
	2+3	300	500	700	900
Heating power (kW)	1	12	24	36	48
	2	12	12	12	24
	3	12	12	24	24
Pump Flow (l/min)	1	300	400	500	620
	2+3	260	350	390	500
Pump Pressure (bar)	1	4	4,5	4,5	5
	2+3	2,5	2,5	2,5	3
Motor (kW)	1	4	7,5	7,5	11
	2	2,2	3	4	4
Connection 3x400V, 50Hz, 3x (A)		63	80	125	160

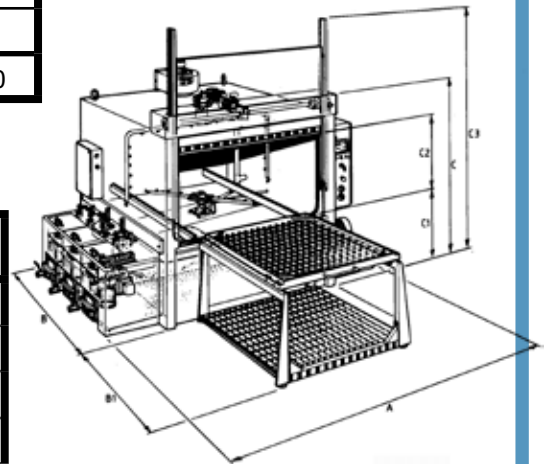
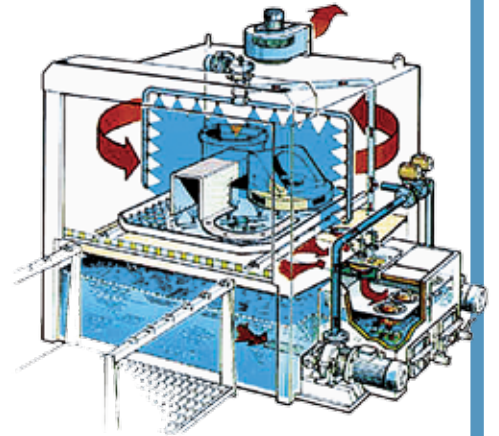

Dimensions	(mm)	SR-1.3-3	SR-1.7-3	SR-2.0-3	SR-2.5-3
Width	A	3 000	3 400	3 800	4 400
Depth	Machine, B	1 600	2 000	2 300	2 800
	Load platform, B1	1 250	1 500	1 700	2 100
Height	Machine, C	2 300	2 300	2 300	2 300
	Loading height, C1	900	900	900	900
	Door Open, C3	3300	3 300	3300	3 300

Load dimensions		SR-1.3-3	SR-1.7-3	SR-2.0-3	SR-2.5-3
Diameter \varnothing	mm	1 100	1 500	1 800	2 300
Height ¹⁾	mm	900	900	900	900
Loadn ²⁾	kg	800	800	1 000	2 000

1) Also other heights as options.

2) Bigger load as an option.

Accessories

- Oil separator
- Filtration systems
- Detergent dosage units
- Drying
- Automation

Sampo Rosenlew Ltd
Konepajanranta 2 A
P.O. Box 50
FI-28101 PORI, FINLAND

Tel. +358 207 550555
Fax +358 26326546
www.sampo-rosenlew.fi

The manufacturer reserves the right to any changes on product or specifications. Images and specifications may vary from the original